

All property rights and rights to exploitation of copyright for this drawing data remain ours; they may not be made available to third parties without our consent.

POS.	Item.No	Artikelbezeichnung	Menge
1	23092801	Welle für FFM/Ø16x924	1
2	16188	Kunststoffrohrschele	4
3	15983	Bügelschlaufe FFM/60x20x2	2
4	15982	Bügel 01/FFM/Ø12x548x169,4	1
5	15981	Scharnier/50x38x2/Kunststoffbuchse/vz.	2

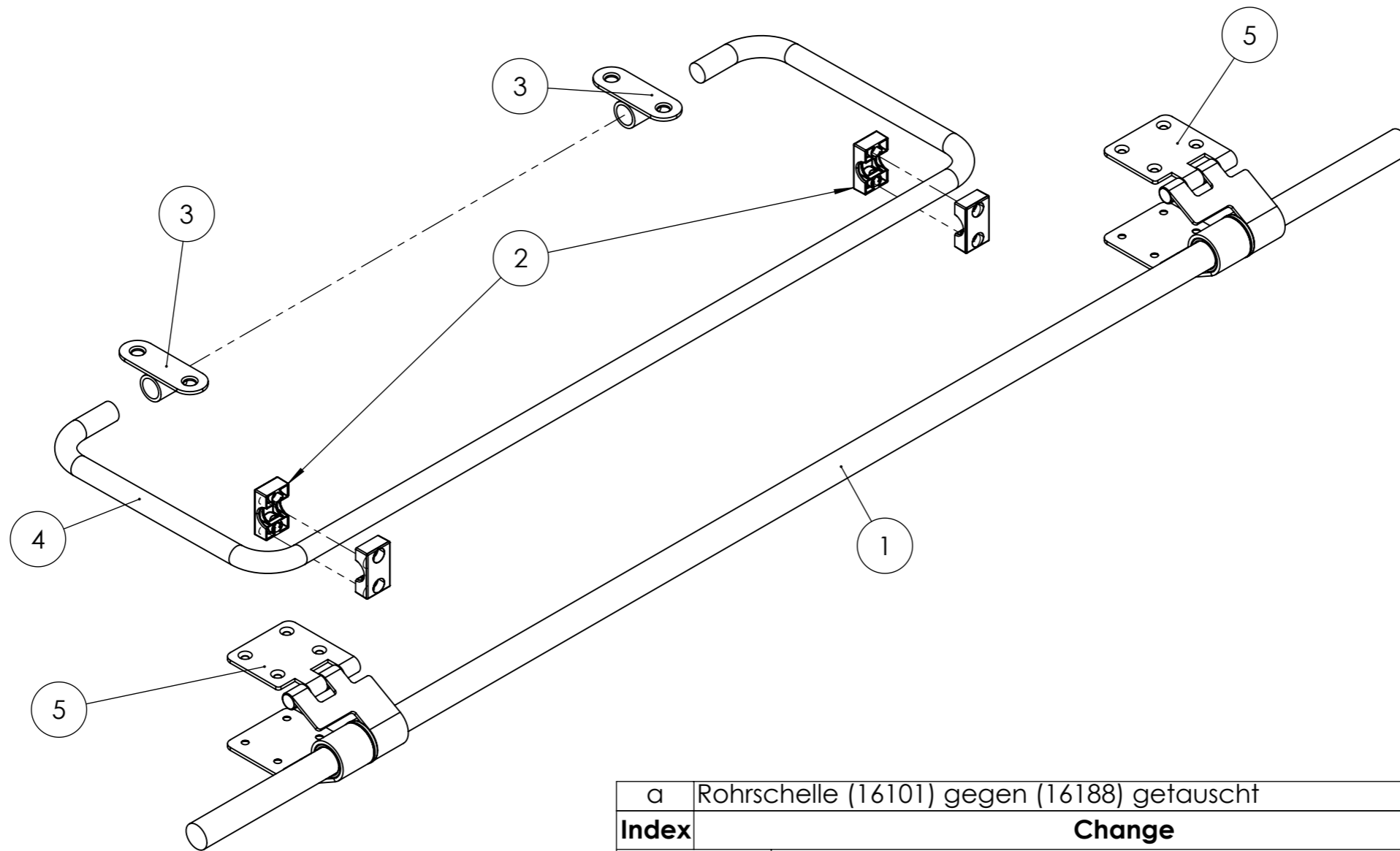

a	Rohrschelle (16101) gegen (16188) getauscht		24.01.2020	A. W.
Index	Change		Date	Name
 DIN ISO 128-30		Description: FFM-SET/WF/B01/W924		
		Surface:	Material: diverse	Weight: 2.42 kg
 Transforming furniture		Name	Date	Company
		Signed	Vandyck	10.07.2018
		Tested	A.Wewior	24.01.2020
General tolerance: DIN ISO 2768 - m		Item No:	57080902	Scale 1:3
		Page	1/8	A3

All property rights and rights to exploitation of copyright for this drawing data remain ours; they may not be made available to third parties without our consent.

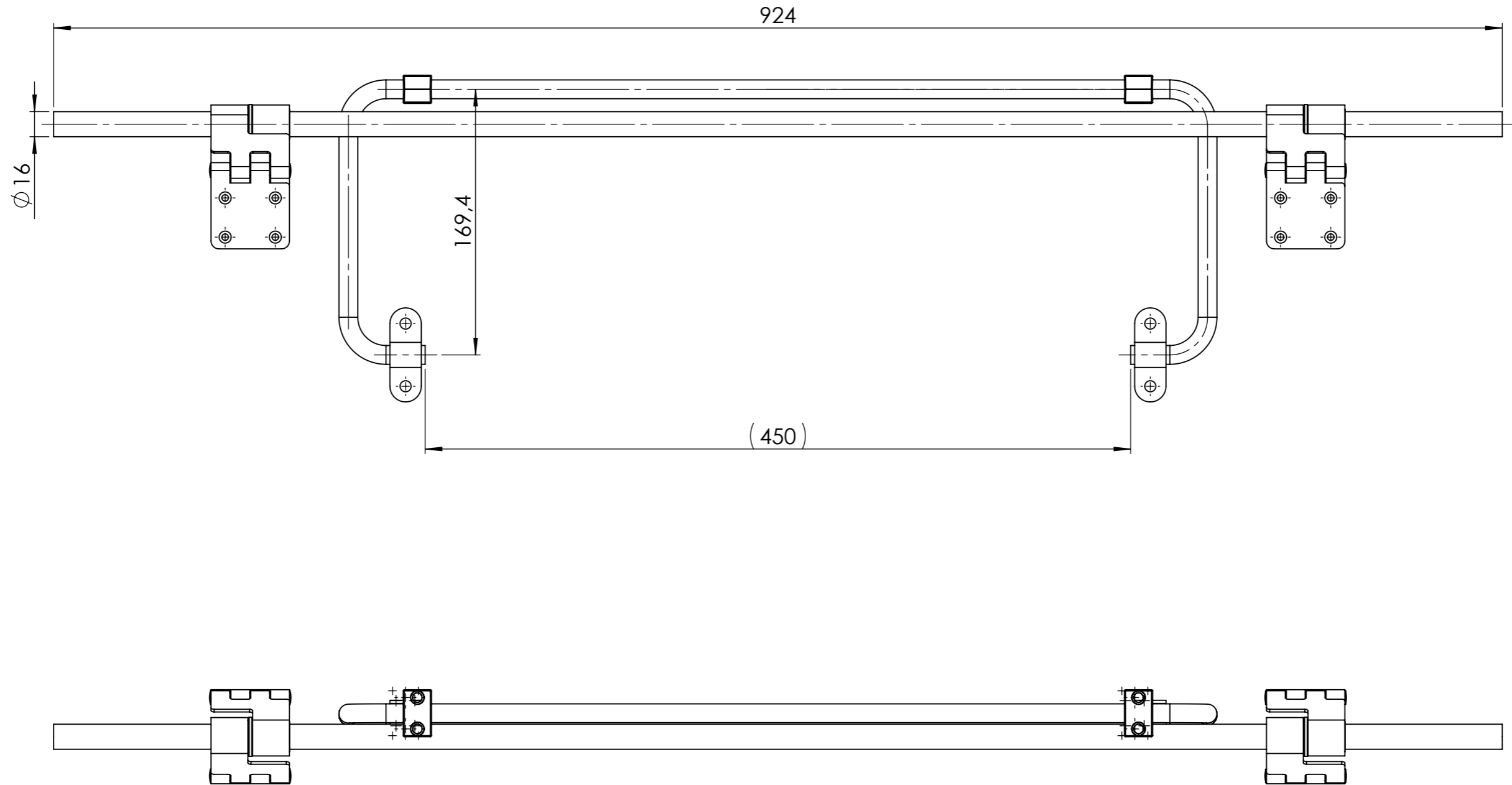

a		2018-083-000		07.04.2018	PVD
 DIN ISO 128-30		Description: FFM-SET/WF/B01/W924			
		Surface:		Material: diverse	Weight: 2.42 kg
PÖTTKER Transforming furniture			Name	Date	Company
		Signed	Vandyck	10.07.2018	
		Tested	A.Wewior	24.01.2020	Second Company:
General tolerance: DIN ISO 2768 - m		Item No: 57080902		Scale 1:3	Page 2/8 A3

Size	Property
A	Table width / 2
B	Table insert
X	B + (min. 100 mm)
Y	A + (min. 100 mm)

Table width	1000 mm
Table insert	2x 800 mm
Table thickness	22 - 28 mm
Butterfly function	Bügel 01 (15982)

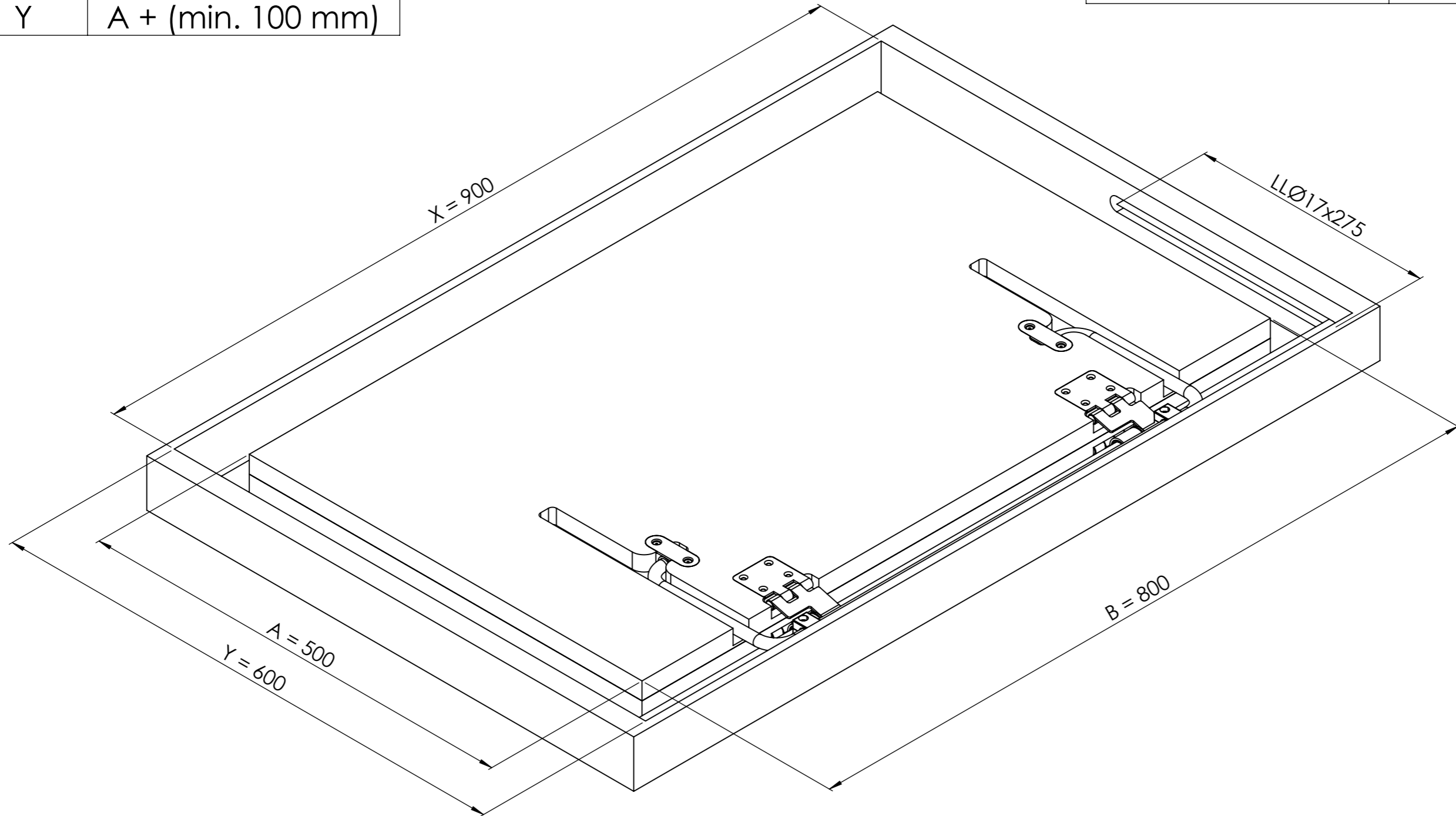

All property rights and rights to exploitation of copyright for this drawing data remain ours; they may not be made available to third parties without our consent.

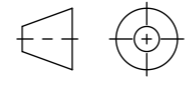
 DIN ISO 128-30	Description: FFM-WF/1000x800/B01/W924		
	Surface:	Material: diverse	Weight: 17.53 kg
PÖTTKER Transforming furniture	Name	Date	Company
	Signed Vandyck	10.07.2018	Second Company:
Tested A.Wewior	24.01.2020	Item No: 2018-208-600	
General tolerance: DIN ISO 2768 - m	Scale 1:4	Page 3/8	A3

DRAWING FOR EXAMPLE

All property rights and rights to exploitation of copyright for this drawing data remain ours; they may not be made available to third parties without our consent.

CLOSE

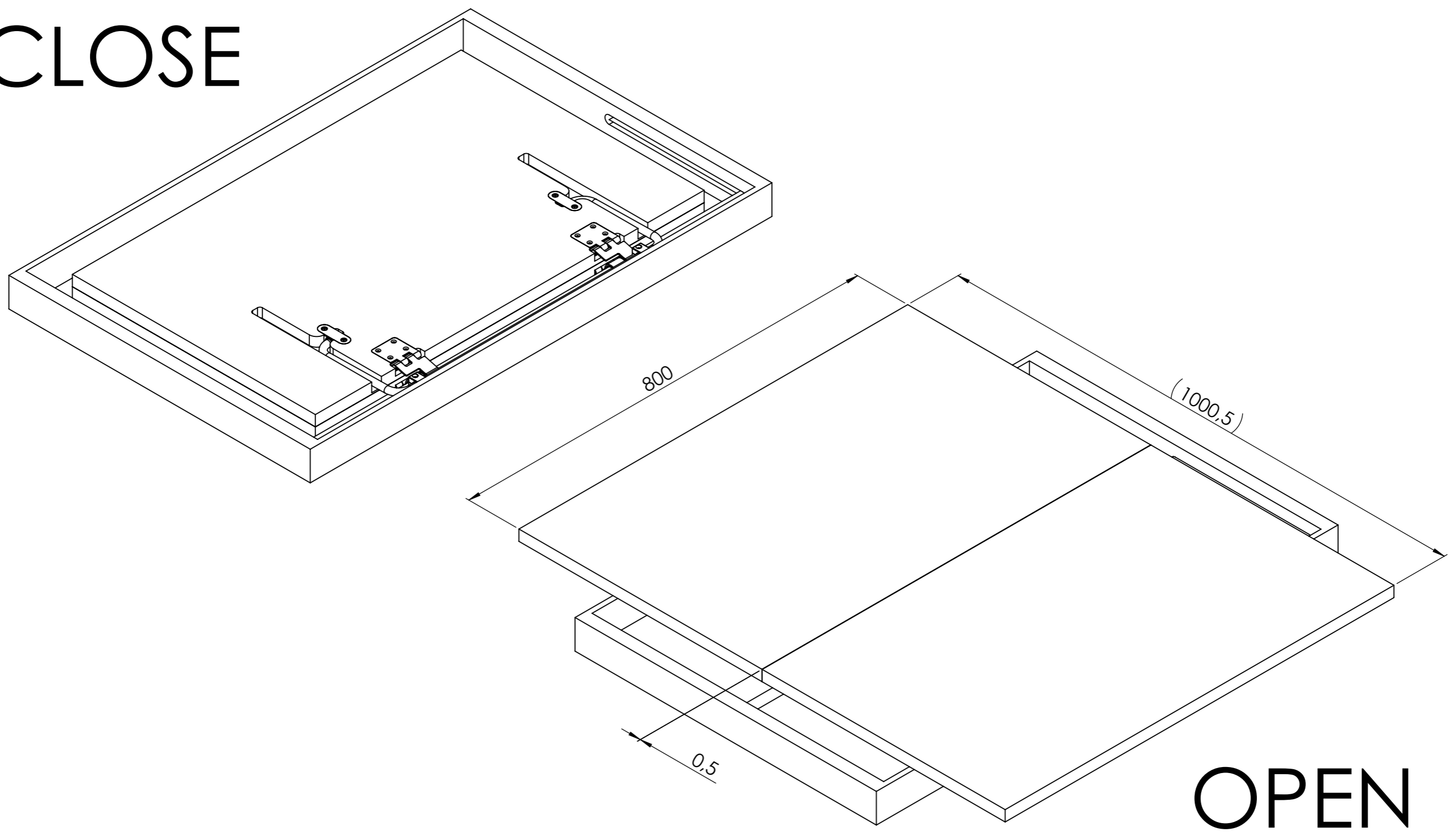

OPEN

DRAWING FOR EXAMPLE

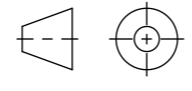
 DIN ISO 128-30	Description: FFM-WF/1000x800/B01/W924			
	Surface:		Material: diverse	
PÖTTKER Transforming furniture	Name	Date	Company	
	Signed Vandyck	10.07.2018	Second Company:	
Tested A.Wewior	24.01.2020	Item No: 2018-208-600		
General tolerance: DIN ISO 2768 - m		Scale 1:6	Page 4/8	A3

All property rights and rights to exploitation of copyright for this drawing data remain ours; they may not be made available to third parties without our consent.

POS.	Item.No	Artikelbezeichnung	Menge
1	57080902	FFM-SET/WF/B01/W924	1
2	2018-067-313-02	Einlegeplatte/FFM-WF/800x500x22/B01	1
3	2018-067-313-01	Einlegeplatte/FFM-WF/800x500x22/B01	1
4	2018-066-323	WF/FFM/600x900x60/LLØ17x275	1

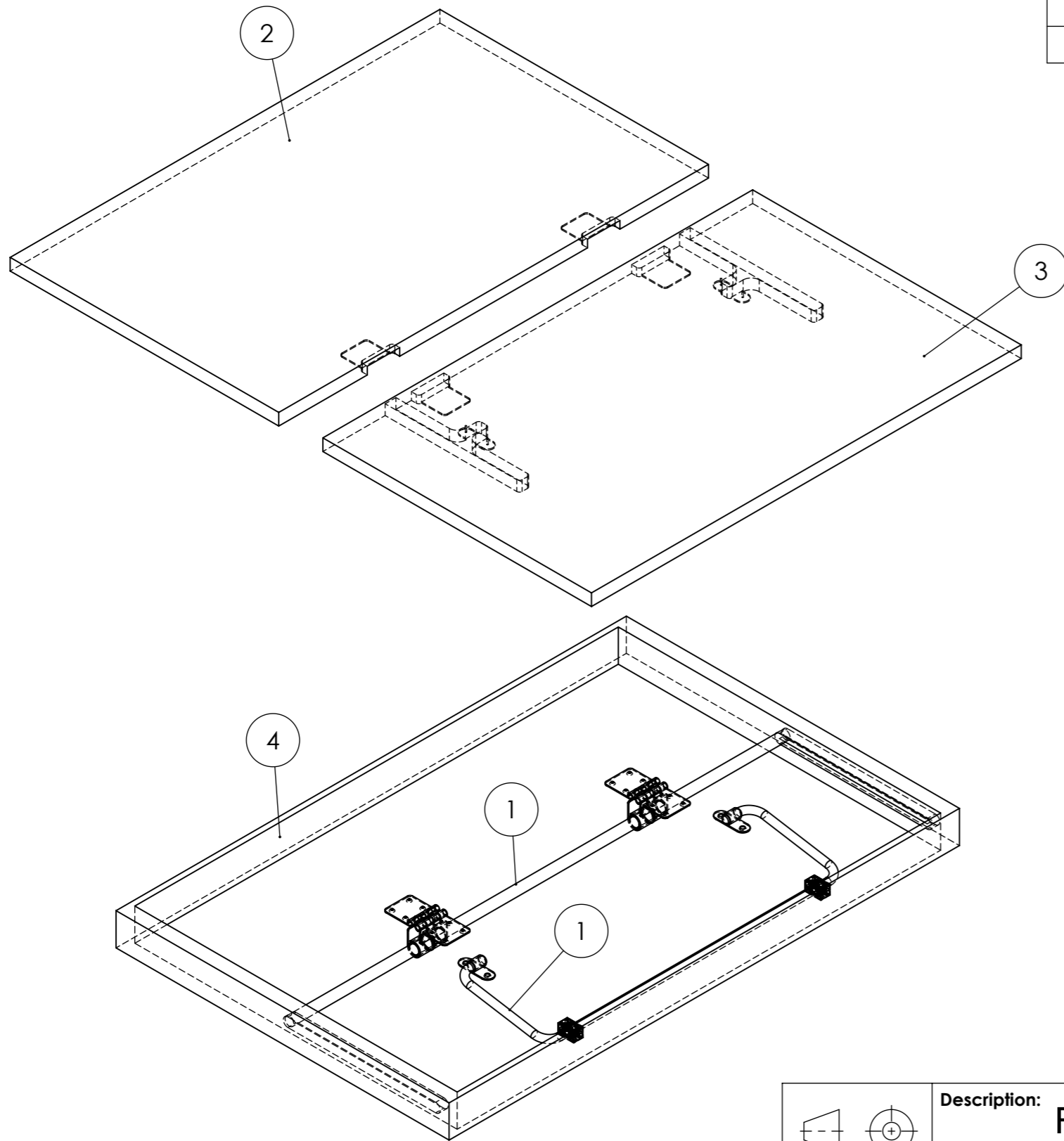

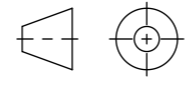
 DIN ISO 128-30	Description: FFM-WF/1000x800/B01/W924				
	Surface:		Material: diverse	Weight: 17.53 kg	
PÖTTKER Transforming furniture	Name	Date	Company		
	Signed	Vandyck	10.07.2018	Second Company:	
Tested	A.Wewior	24.01.2020			
General tolerance: DIN ISO 2768 - m		Item No: 2018-208-600	Scale: 1:7	Page: 5/8	A3

DRAWING FOR EXAMPLE

All property rights and rights to exploitation of copyright for this drawing data remain ours; they may not be made available to third parties without our consent.

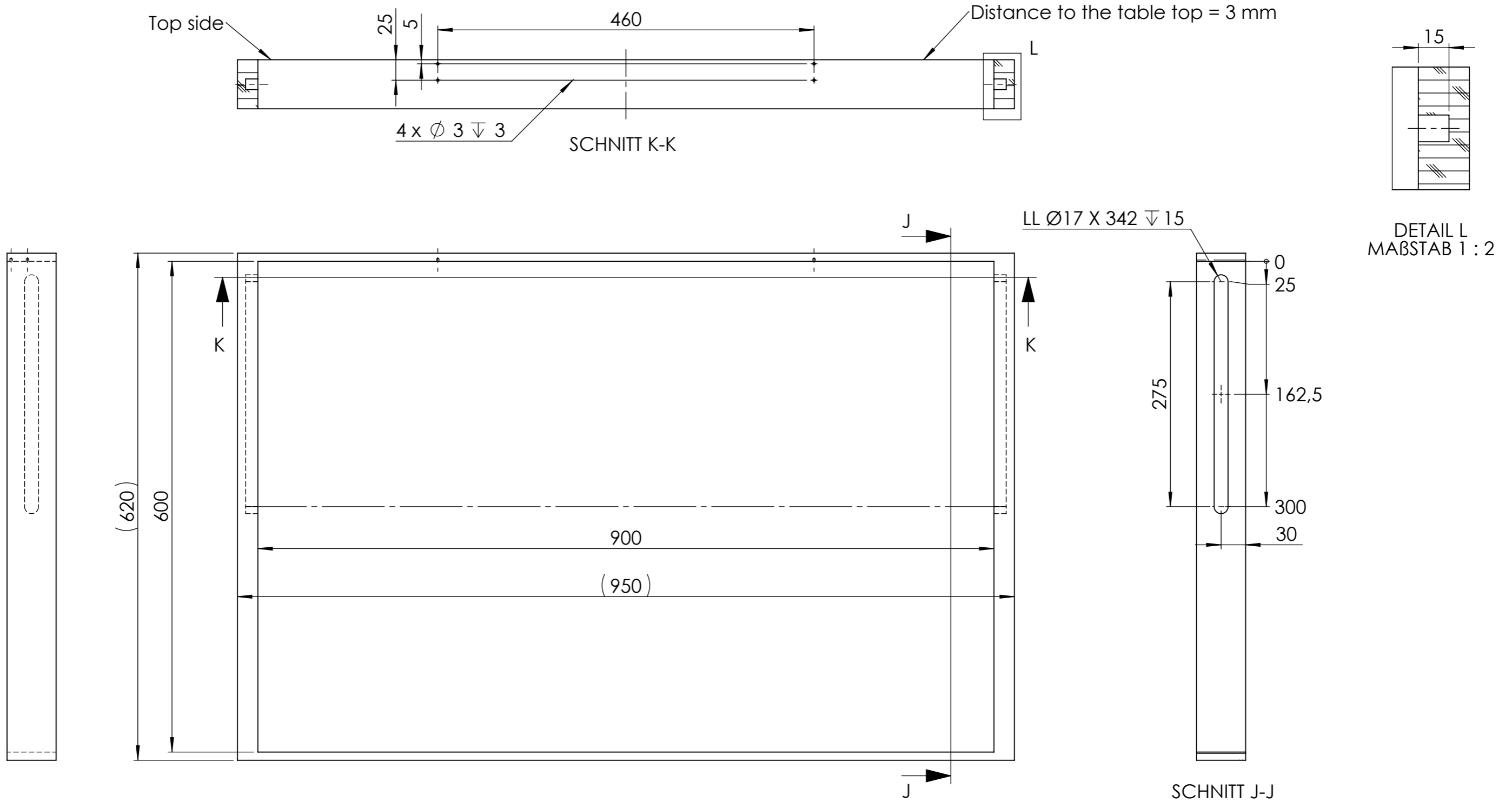

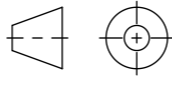
Index	Change			Date	Name
 DIN ISO 128-30	Description: WF/FFM/600x900x60/LLØ17x275				
	Surface:		Material: o.A.		Weight: 1.56 kg
PÖTTKER Transforming furniture		Name	Date	Company	
	Signed	Vandyck	10.07.2018		
	Tested	A.Wewior	24.01.2020	Second Company:	
General tolerance: DIN ISO 2768 - m		Item No: 2018-066-323	Scale 1:5	Page 6/8	A3

DRAWING FOR EXAMPLE

All property rights and rights to exploitation of copyright for this drawing data remain ours; they may not be made available to third parties without our consent.

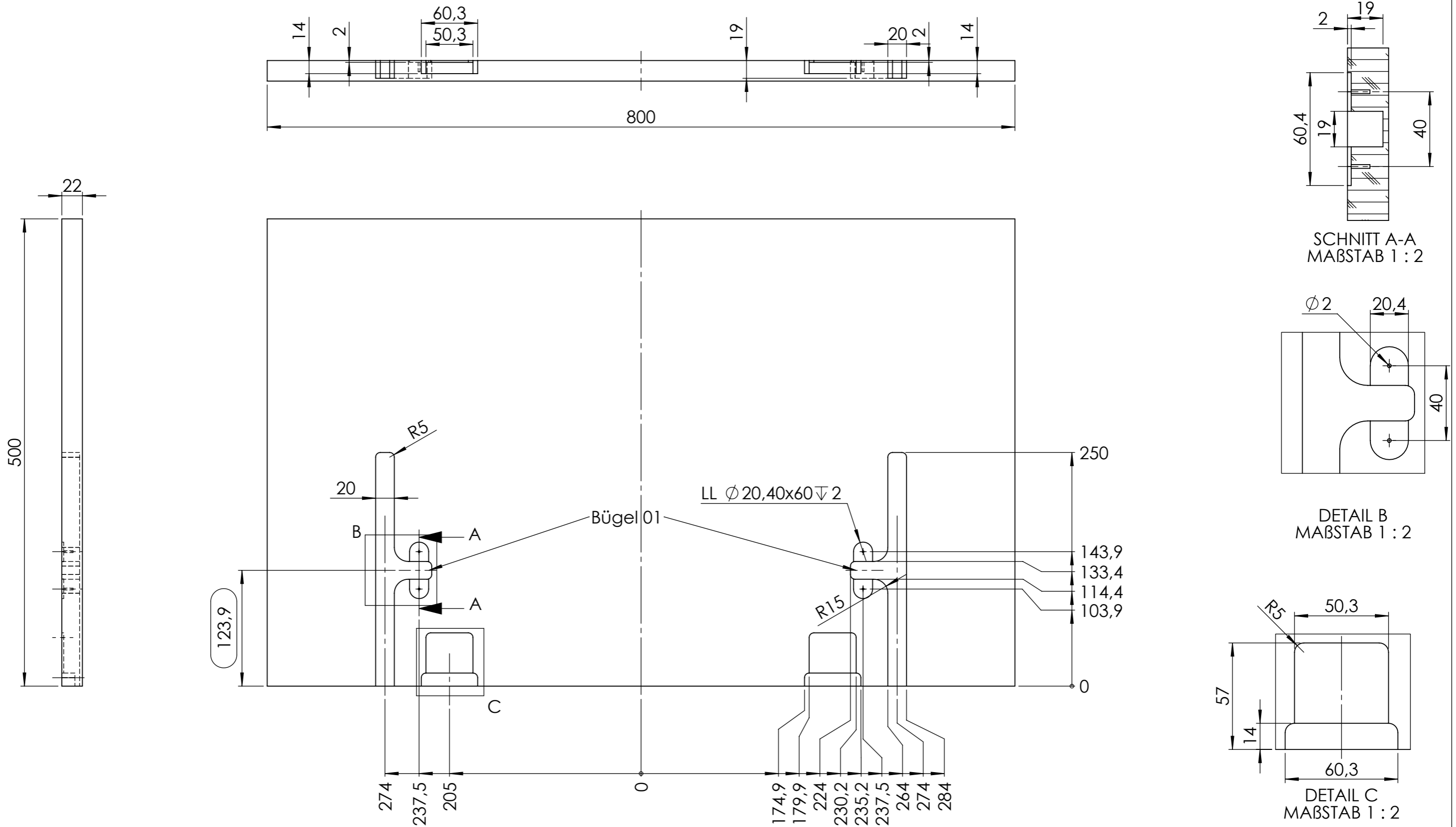

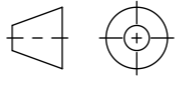
		Description: Einlegeplatte/FFM-WF/800x500x22/B01			
Surface:		Material: o.A.		Weight: 4.78 kg	
PÖTTKER Transforming furniture	Name	Date	Company		
	Signed	Vandyck	10.07.2018	Second Company:	
	Tested	A.Wewior	24.01.2020	Second Company:	
General tolerance: DIN ISO 2768 -1		Item No:	2018-067-313-01	Scale 1:4	Page 7/8

DRAWING FOR EXAMPLE

All property rights and rights to exploitation of copyright for this drawing data remain ours; they may not be made available to third parties without our consent.

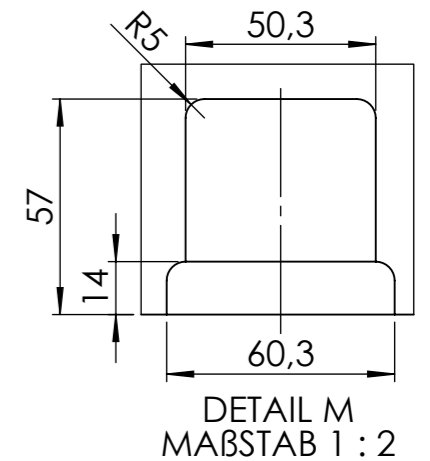
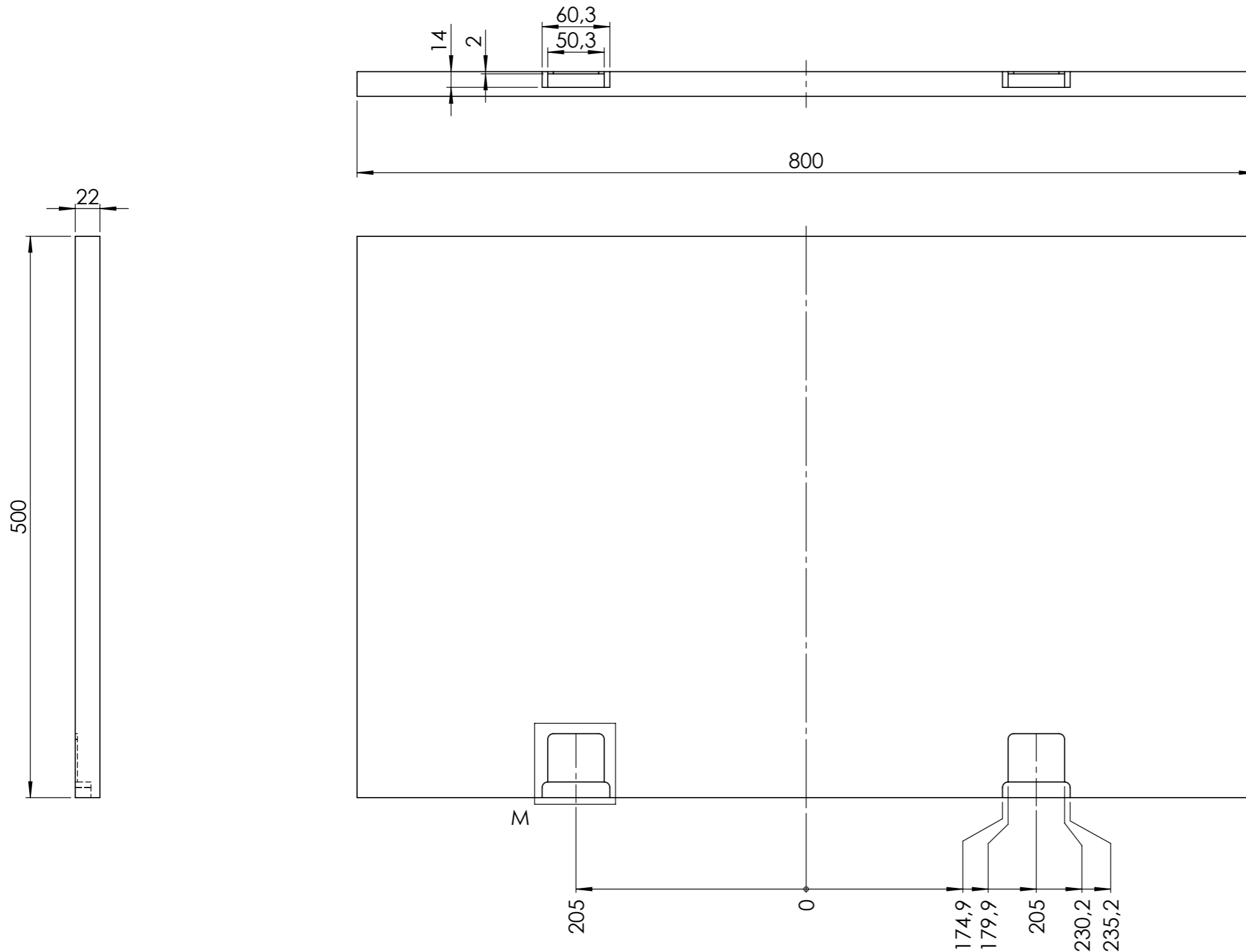

<p>DIN ISO 128-30</p>	Description: Einlegeplatte/FFM-WF/800x500x22/B01					
	Surface:		Material: o.A.		Weight: 4.78 kg	
<p>PÖTTKER Transforming furniture</p>	Name	Date	Company			
	Signed	Vandyck	10.07.2018	Second Company:		
	Tested	A.Wewior	24.01.2020			
General tolerance: DIN ISO 2768 -1		Item No:	2018-067-313-02	Scale 1:4	Page 8/8	A3

DRAWING FOR EXAMPLE