

# EPOXY SLIDES

## F12E 86mm Metal Side Panel Slides



### PRODUCT



### DESCRIPTION

- Load capacity: 25kg
- Self-closing
- Double stop positions
- 2-D front panel adjustment
- Screw on/plug in bottom panel
- Lengths: 250-550mm
- Finish: white(E01)/Silver grey(E07)

### SPACE REQUIREMENT

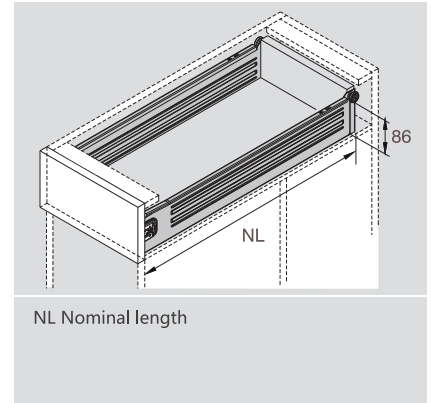

### LOWER DRAWER FOR WOOD DRAWER BACK

1		Slides (left/right)	
		White(E01)/ Silver Grey(E07)	
NL		Thickness 1.2mm Item No.	Set/ctn
250mm		<b>F12E100</b>	10
270mm		<b>F12E110</b>	10
300mm		<b>F12E120</b>	10
350mm		<b>F12E140</b>	10
400mm		<b>F12E160</b>	10
450mm		<b>F12E180</b>	10
500mm		<b>F12E200</b>	10
550mm		<b>F12E220</b>	10

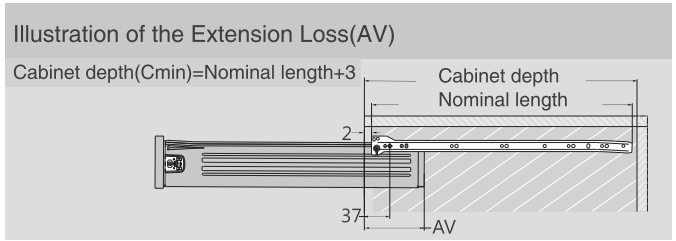

4		Front Fixing-brackets (left/right)	
		Nickel Plated(A02)	
		Item No.	Pcs/ctn
Screw-on		<b>L1M</b>	200
Press-in		<b>L1MM</b>	200

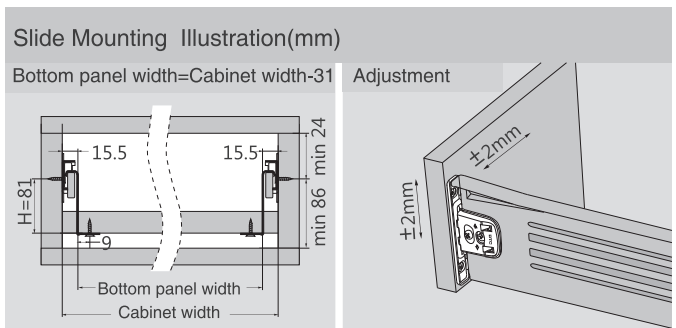

Screw Positions of the Slides(mm)	
	NL
	250
	270
	300
	350
	400
	450
	500
	550

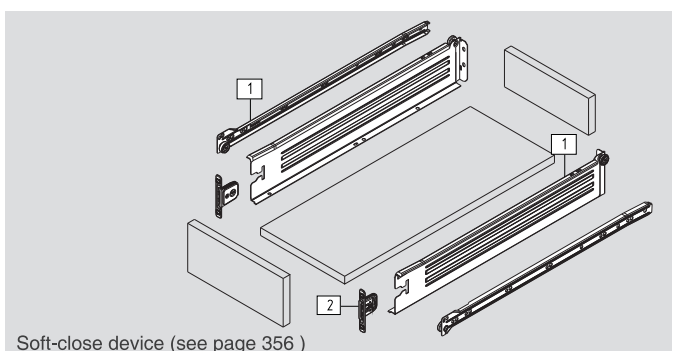
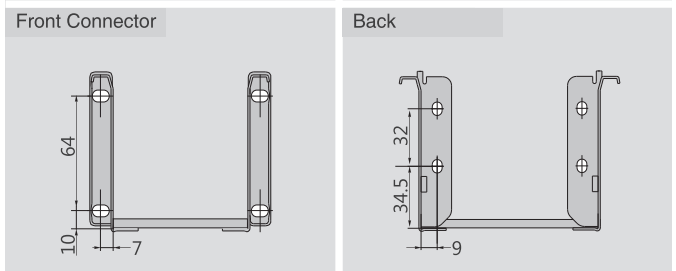

Soft-close device (see page 356)